

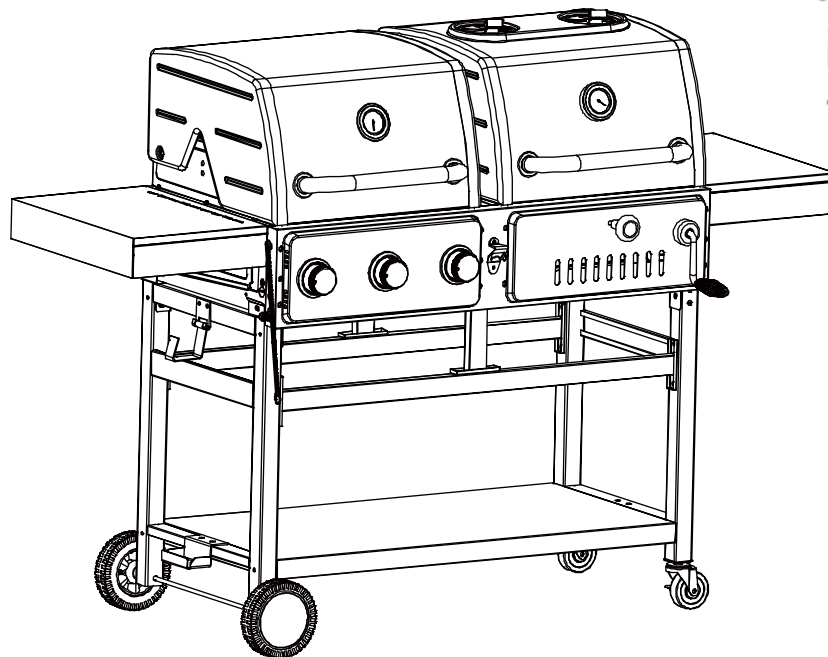

ASSEMBLY GUIDE

Model: ZH3003



Durable 3-Burner Gas/Charcoal Combo Grill

FOR YOUR SAFETY!

Use outdoors only! Do not use it in a building, garage or any other enclosed areas.
Read the instructions before assembling and using the appliance.
DO NOT use the grill unless it is completely assembled and all the parts are securely fastened.
This grill will become very hot, do not move it during operation. Keep children and pets away.









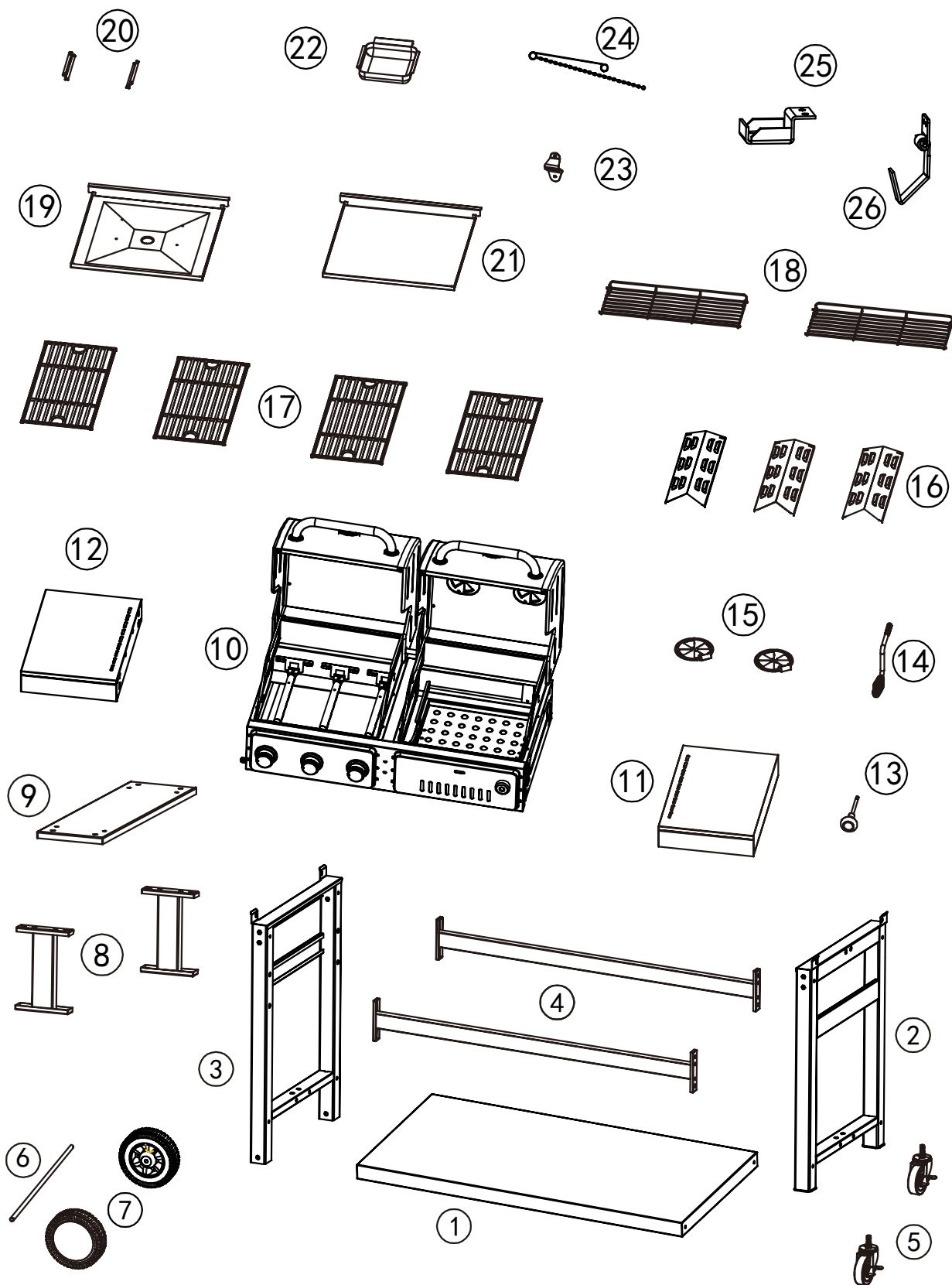

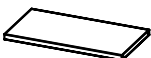















CONTACT US FIRST!









This grill has been made to high quality standards. If you have any questions that are not addressed in this manual, or you need parts, please call our customer service hotline or send an email to service@royalgourmetusa.com

Learn more at:

www.royalgourmetcorp.com



Ref	Description	Illustration	QTY	Ref	Description	Illustration	QTY
1.	Bottom shelf		1	14.	Lifting handle		1
2.	Right side shelf		1	15.	Airvent cover		2
3.	Left side shelf		1	16.	Flame tamer		3
4.	Cart beam		2	17.	Cooking grate		4
5.	Caster		2	18.	Warming rack		2
6.	Wheel axle		1	19.	Grease tray		1
7.	Wheel & cover		2	20.	Grease cup brace		2
8.	Middle brace		2	21.	Ash pan		1
9.	Middle shelf		1	22.	Grease cup		1
10.	Fireboxes		1	23.	Bottle opener		1
11.	Side table (R)		1	24.	Extention wire		1
12.	Side table (L)		1	25.	Tank base		1
13.	Airvent handle		1	26.	Tank hook		1

A	M6x12	44pcs	B	Washer	2pcs	C	M5x10	2pcs	D	M4x8	4pcs	E	M6x50	4pcs	
															
F	M6	8pcs	G	M4	4pcs	H	Split pin	2pcs							
															

Before beginning assembly, make sure all parts are present. Compare parts with packaged contents list and diagram above. If any parts are missing or damaged, do not attempt to assemble the products. Contact customer service for replacement parts via telephone or email.



Phillips Screwdriver



Wrench

- Estimated assembly time: 40 minutes
- Tools required for assembly:
Phillips Screwdriver (not included) and Wrench (not included)
- Note: The right and left sides of the grill are designed as if you are facing the front of the grill.

Step 1

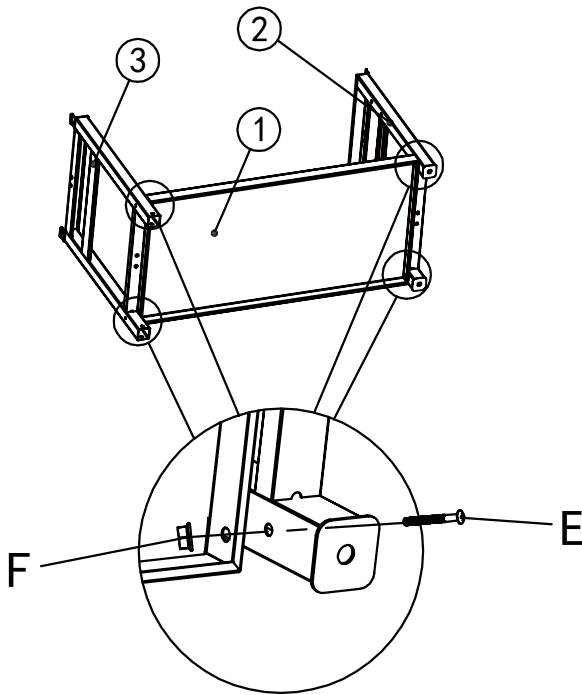

Assemble the right side shelf (2) and left side shelf (3) to the bottom shelf (1) with 4 bolts (E) and 4 nuts (F) as shown.

Step 2

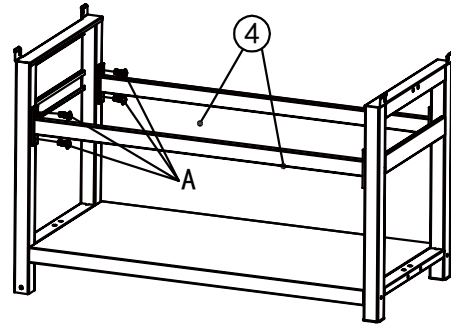

Assemble the cart beam (4) to side shelves with 8 bolts (A).

Step 3

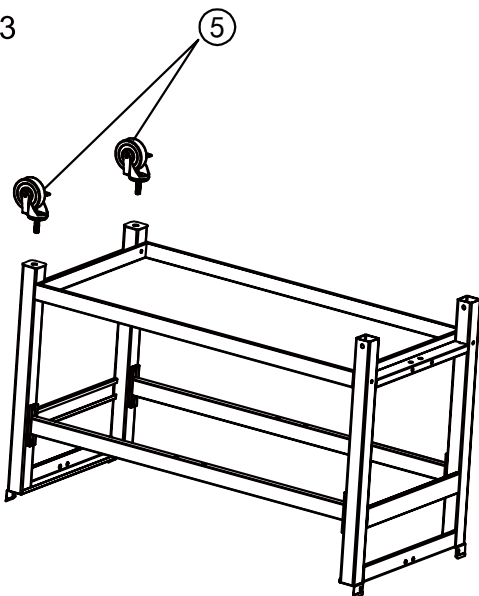

Assemble the casters (5) to right side shelf (2), twist clockwise.

Step 4

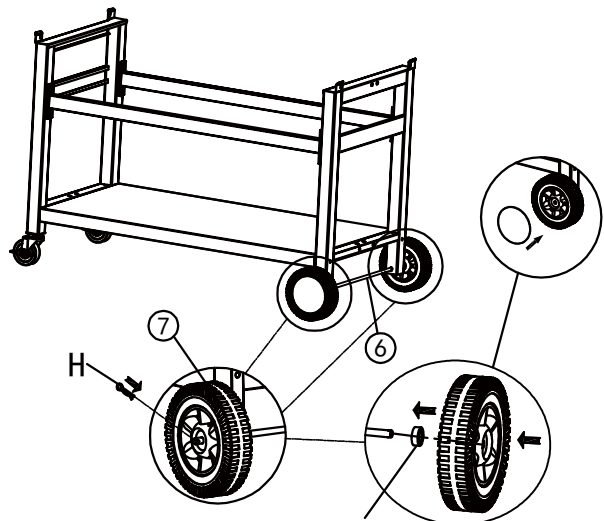

Slide the wheel axle (6) through the left side shelf (3), attach the wheel washers (B) and wheels (7) on the axle from both sides. Secure them with 2 split pins (H). Attach the wheel cover back to the wheels.

Step 5

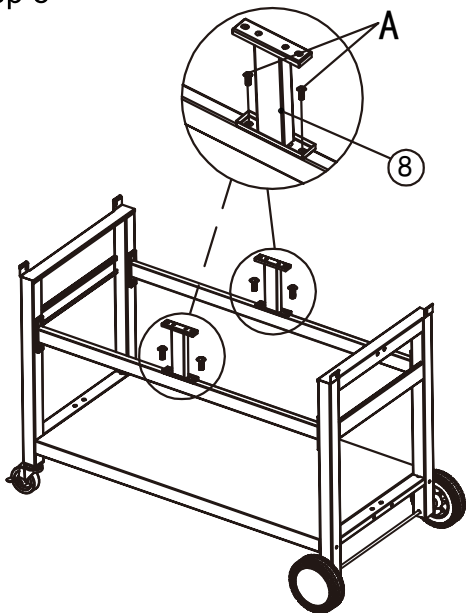

Fasten the middle braces (8) to cart beams with 4 bolts (A).

Step 6

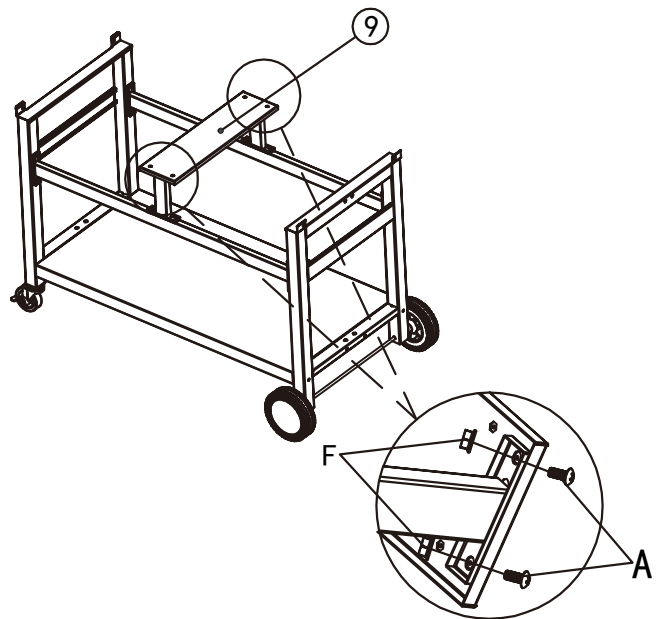

Assemble the middle shelf (9) to the middle braces with 4 bolts (A) and 4 nuts (F).

Step 7

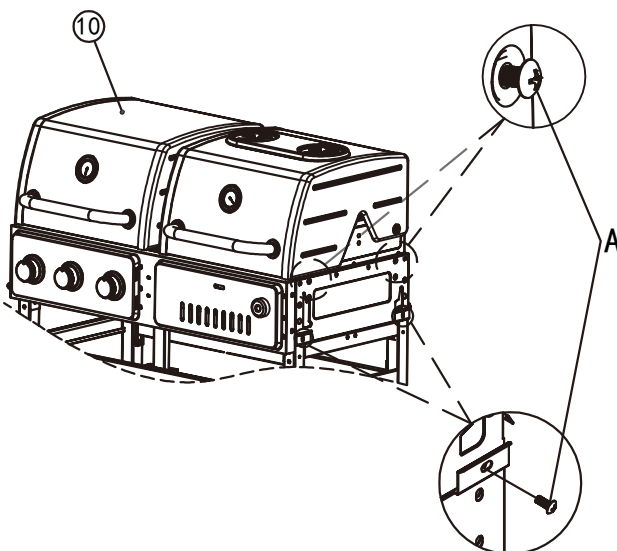

Align and place the fireboxes (10) onto the cart, fasten them to cart braces with 4 bolts (A). Half screw 4 bolts (A) to shown positions of the fireboxes.

Step 8

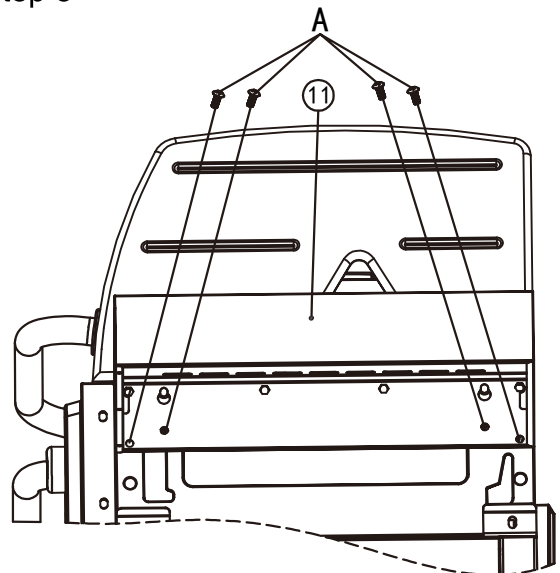

Assemble the right side table (11) to the fireboxes by hanging it to the half screwed bolts, fasten it with 4 bolts (A). Then secure the half screwed bolts.

Step 9

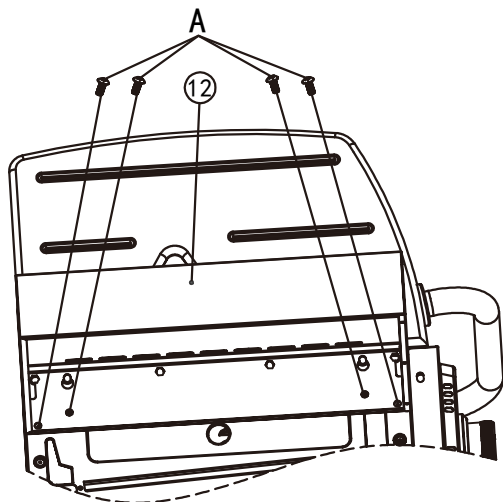

Assemble the right side table (12) to the fireboxes by hanging it to the half screwed bolts, fasten it with 4 bolts (A). Then secure the 2 bolts half screwed.

Step 10

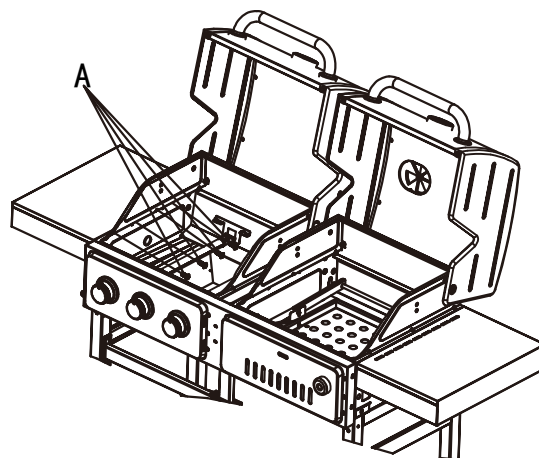

Fasten the side tables from the inside of fireboxes with 8 bolts (A).

Step 11

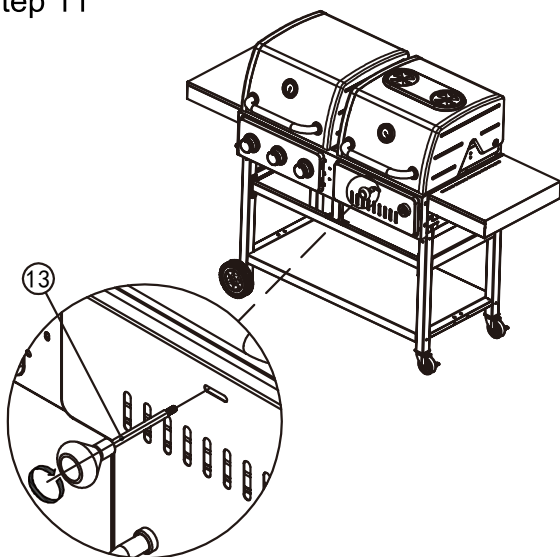

Screw the airvent handle (13) to the control panel twist clockwise.

Step 12

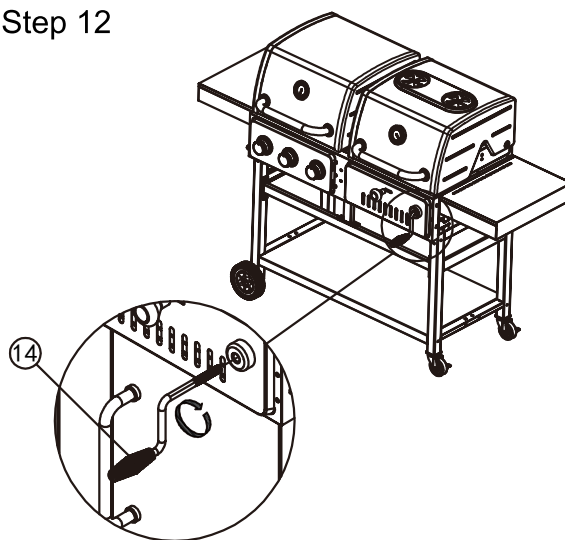

Screw the lifting handle (14) to the control panel twist clockwise.

Step 13

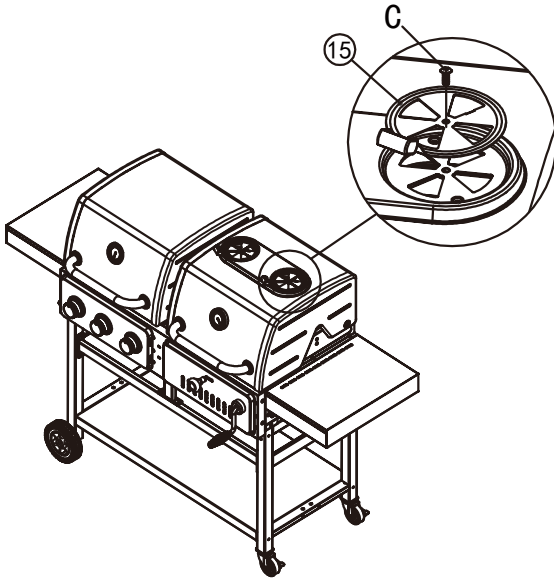

Install the airvent covers (16) to the charcoal lid with 2 bolts (C).

Step 14

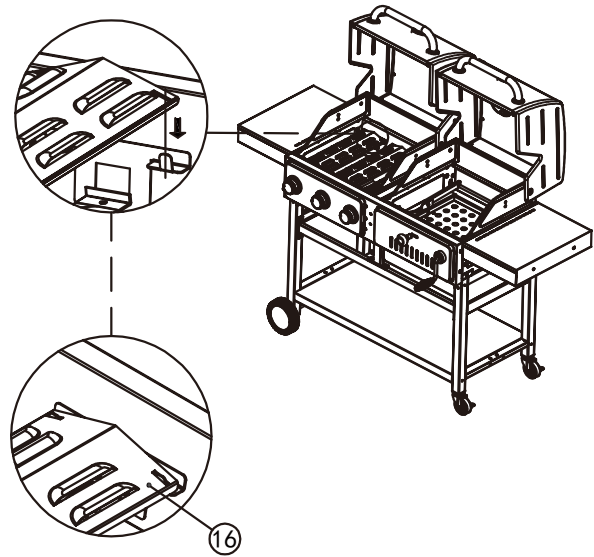

Place the flame tamers (16) into the gas grill.

Step 15

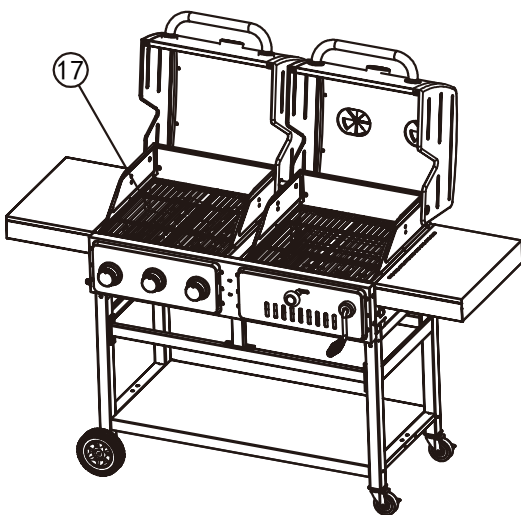

Place the cooking grates (17) into the fireboxes.

Step 16

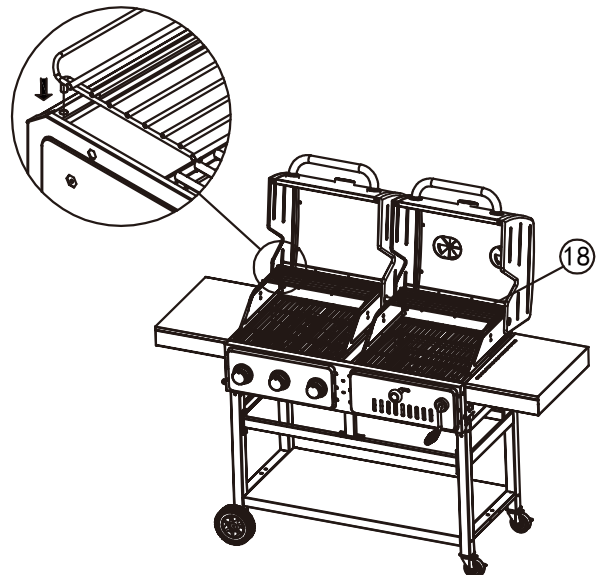

Place the warming racks (18) into the fireboxes.

Step 17

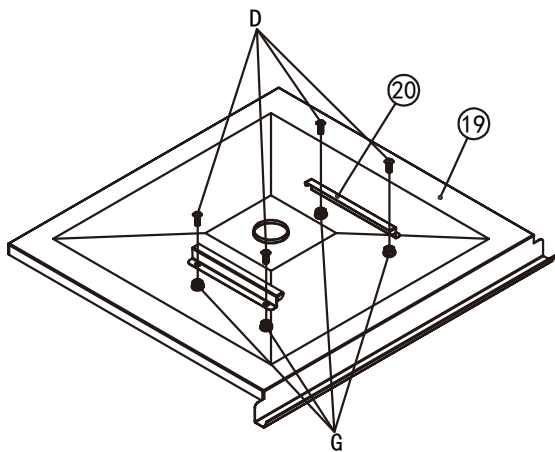

Assemble the grease cup brace (22) to the grease tray (21) with 4 bolts (D) and 4 nuts (G).

Step 18

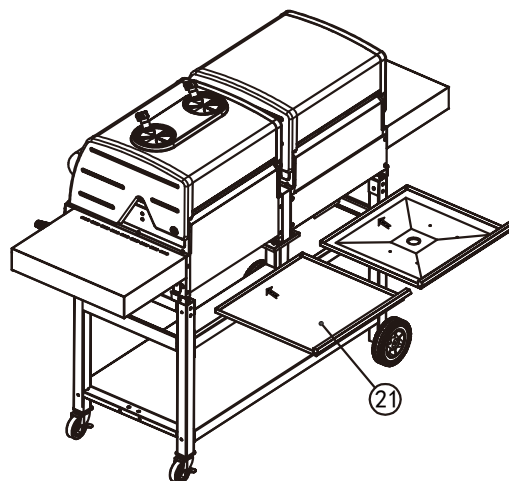

Slide the ash pan (23) and grease tray (21) underneath the fireboxes.

Step 19

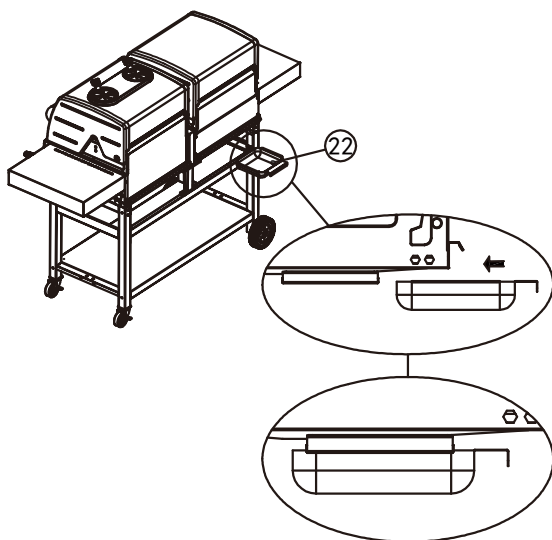

Attach the grease cup (22) underneath the grease tray .

Step 20

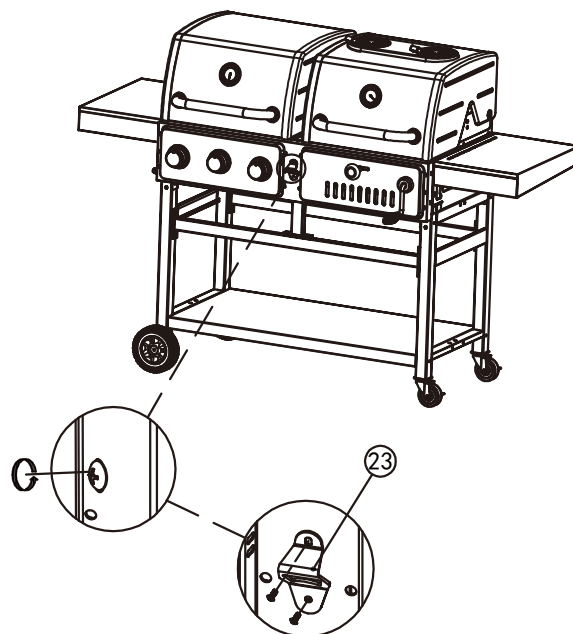

Loosen 2 bolts of the middle of control panel, fasten the bottle opener (23) to fireboxes, screw back the bolts as shown.

Step 21

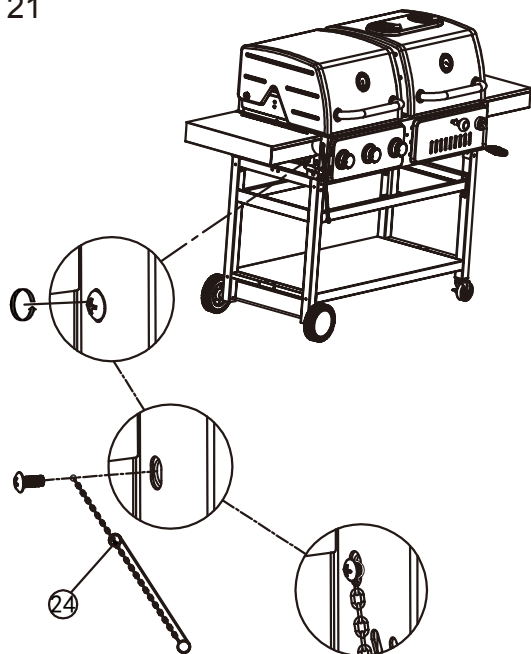

Loosen 1 bolt of left side of control panel, fasten the extension wire (24) to main body, screw back the bolt as shown.

Step 22

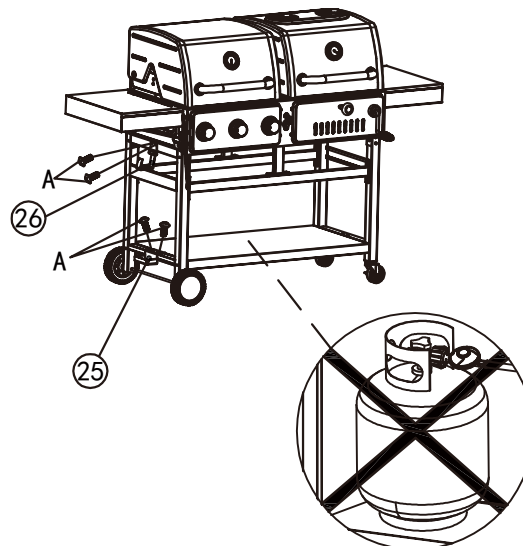

Fasten the tank hook (26) to side cart brace with 2 bolts (A).
Fasten the tank base (25) to bottom shelf with 2 bolts (A).